

POWER MILLING CHUCK

- Very high clamping force and High stability improving surface quality and tool life time.
- Optimised design resulting in Ideal damping characteristics and low vibration.
- Radial run-out less than 0.01mm.
- For clamping cutting tools with cylindric shank tolerance h6
- Flexible clamping range by using reducing sleeve for various tool shank.

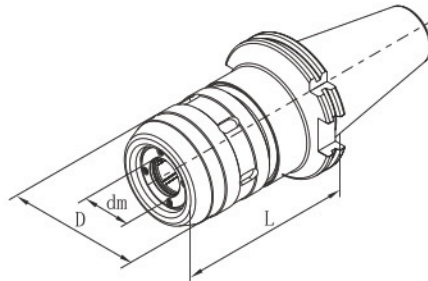
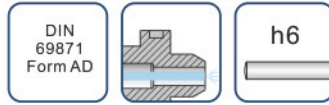

Order No.	Model	Shank	Size(mm)			For Collets	Wrench
			dm	D	L		
132-03-401	JT40-C20-95	SK40-AD	20	55	95	C20	WC20
132-03-402	JT40-C25-100	SK40-AD	25	62	100	C25	WC25
132-03-403	JT40-C32-105	SK40-AD	32	72	105	C32	WC32
132-03-501	JT50-C20-105	SK50-AD	20	55	105	C20	WC20
132-03-502	JT50-C25-110	SK50-AD	25	62	110	C25	WC25
132-03-503	JT50-C32-110	SK50-AD	32	72	110	C32	WC32
132-03-504	JT50-C42-110	SK50-AD	42	87	110	C42	WC42

POWER MILLING CHUCK SET

- Each set including 1pc of SK40-AD power milling chuck and 6pc of reducing sleeve, Equipped with wrench and pack in strong aluminium box.
- Long working life time du to system radial run-out less than 0.01mm.



REDUCING SLEEVE FOR POWER MILLING CHUCK

- For drill,milling,reaming.
- Radial run-out less than 0.01mm
- For clamping cutting tools with cylindric shank tolerance h6

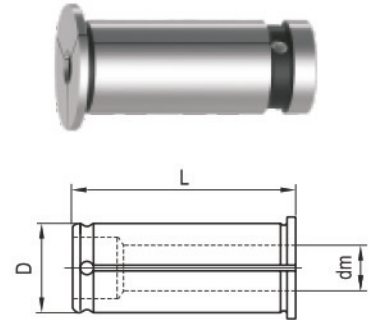

Order No.	Modle	Size (mm)		
		dm	D	L
100-03-001	C20-3	3	20	55
100-03-002	C20-4	4	20	55
100-03-003	C20-5	5	20	55
100-03-004	C20-6	6	20	55
100-03-005	C20-8	8	20	55
100-03-006	C20-10	10	20	55
100-03-007	C20-12	12	20	55
100-03-008	C20-14	14	20	55
100-03-009	C20-16	16	20	55
100-03-010	C25-4	4	25	60
100-03-011	C25-5	5	25	60
100-03-012	C25-6	6	25	60
100-03-013	C25-8	8	25	60
100-03-014	C25-10	10	25	60
100-03-015	C25-12	12	25	60
100-03-016	C25-14	14	25	60
100-03-017	C25-16	16	25	60
100-03-018	C25-18	18	25	60
100-03-019	C25-20	20	25	60

Order No.	Modle	Size (mm)		
		dm	D	L
100-03-020	C32-6	6	32	65
100-03-021	C32-8	8	32	65
100-03-022	C32-10	10	32	65
100-03-023	C32-12	12	32	65
100-03-024	C32-14	14	32	65
100-03-025	C32-16	16	32	65
100-03-026	C32-18	18	32	65
100-03-027	C32-20	20	32	65
100-03-028	C32-25	25	32	65
100-03-029	C42-6	6	42	70
100-03-030	C42-8	8	42	70
100-03-031	C42-10	10	42	70
100-03-032	C42-12	12	42	70
100-03-033	C42-14	14	42	70
100-03-034	C42-16	16	42	70
100-03-035	C42-18	18	42	70
100-03-036	C42-20	20	42	70
100-03-037	C42-25	25	42	70
100-03-038	C42-32	32	42	70

Order No.	content		
	1pc chuck	1pc each size of reducing sleeve	1pc wrench
111-03-S04	JT40-C32-105	C32-8,C32-10,C32-12,C32-16,C32-20,C32-25 (internal dia:8,10,12,16,20,25mm)	WC32
111-03-S05	JT50-C32-110	C32-8,C32-10,C32-12,C32-16,C32-20,C32-25 (internal dia:8,10,12,16,20,25mm)	WC32